

EXPRESS XT DC

FROM 200-600 GPD (760-2,270 LPD) OF PURE WATER

PURE WATER FOR SMALL
TO MID-SIZED YACHTS



The Blue Water Express XT DC series watermakers feature automatic operation with capacities up to 25 gallons per hour (95 liters per hour). Designed to fit into tight spaces of small and mid-sized yachts, the Express XT DC is ideal for applications in today's cruising yachts that rely solely on DC power while away from the marina.

- Fully automatic operation
- Simple LCD screen controller
- Available in compact or modular configurations
- Standard Fresh water flush system included
- High rejection membranes
- Available in 12V, 24V & 48V DC
- Quiet and reliable high pressure pumps
- Optional remote control



THE NEXT EVOLUTION IN
WATERMAKER DESIGN

FULL LINE OF WATERMAKERS
FROM 200 TO 3,400 GPD

WORLDWIDE SALES, PARTS
AND EXPERT SERVICE

EXPRESS XT DC

FROM 200-600 GPD (760-2,270 LPD) OF PURE WATER

DRAWINGS & SPECIFICATIONS

Model	Hourly Production	Daily Production	Feed Flow	Weight
EX XT DC 200	8 GPH / 32 LPH	200 GPD / 760 LPD	0.5 GPM	130 lbs / 59 kg
EX XT DC 360	15 GPH / 57 LPH	360 GPD / 1,360 LPD	1.0 GPM	135 lbs / 61 kg
EX XT DC 600	25 GPH / 95 LPH	600 GPD / 2,270 LPD	1.5 GPM	140 lbs / 64 kg

Model	Booster Pump	HP Pump	Run Amps 12V	Run Amps 24V	Run Amps 48V
EX XT DC 200	0.10 HP / 0.075 KW	0.33 HP / 0.25 KW	34	17	8.5
EX XT DC 360	0.10 HP / 0.075 KW	0.75 HP / 0.56 KW	66	33	16.5
EX XT DC 600	0.10 HP / 0.075 KW	1 HP / 0.75 KW	88	43	22

Vessel Assembly

(EX XT DC 600) - 37.8" | 961mm
 (EX XT DC 360) - 27.8" | 706mm
 (EX XT DC 200) - 24.0" | 609mm

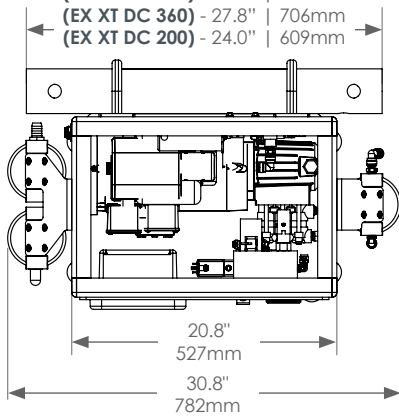

Compact Frame Top View

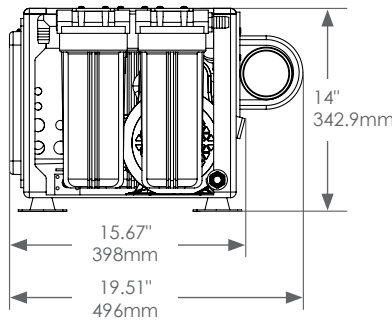

Compact Frame Side View

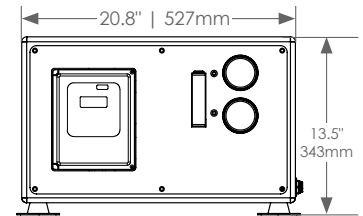
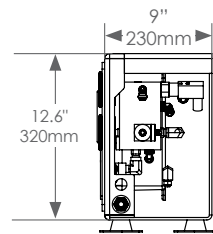

Modular Controller

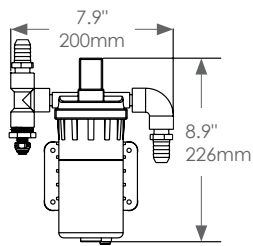

Booster Pump (12V/24V)

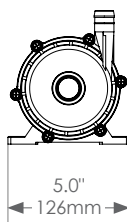

Booster Pump (48V)

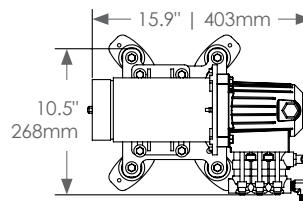

HP Pump (EX XT DC 200)

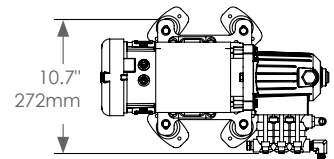

HP Pump (EX XT DC 360/600)

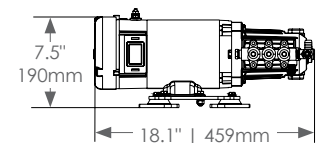
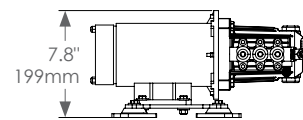
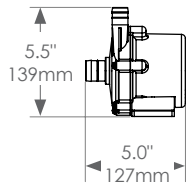
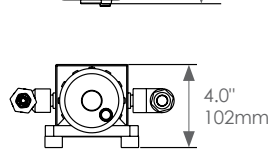

ADDITIONAL DRAWINGS AVAILABLE AT: BLUEWATERDESALINATION.COM/WATERMAKERS/EXPRESS-XT-DC